

Raita



PUMPPAAMOT



PUMP STATIONER



PUMPING STATIONS

D1800

24 h

D1800

Säiliöt D1200 mm ovat (PE) muovia (rotaatiovalettu
kestävyys standardin EN 12566- 1 - VTT -S-06698-13)

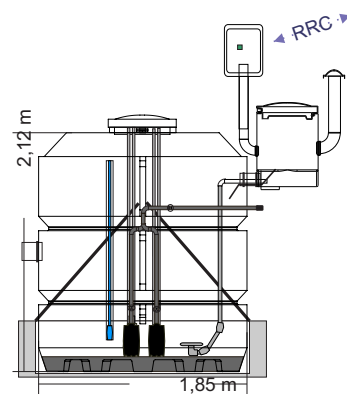
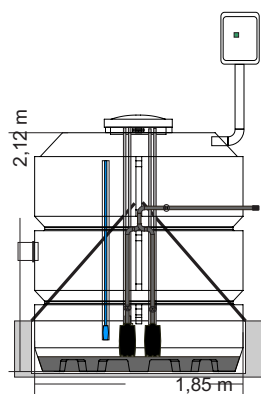
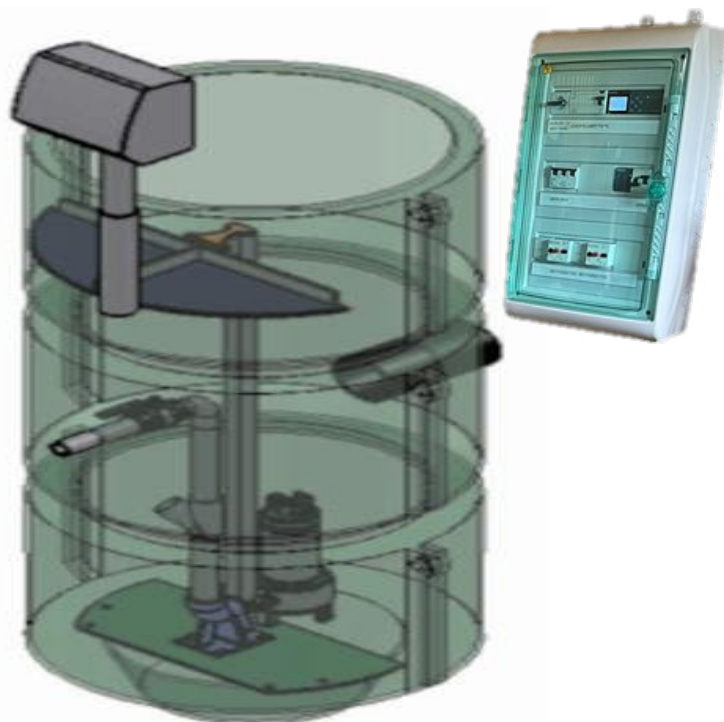
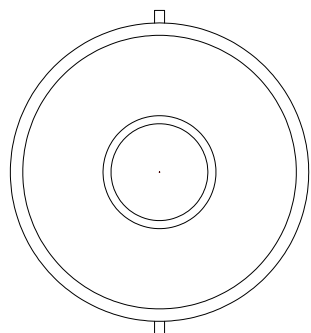
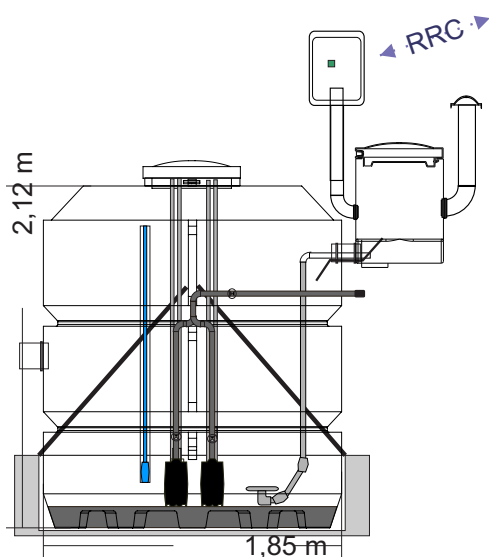

Linkejä lisämateriaaliin:

[Manual pumppaamo](#)

[Mallisto - piirustukset](#)

[Sertifikaatti PE](#)

[Sertifikaatti lasikuitu](#)

[Takuu \(10 vuotta\) lomake \(maa-asennus opas\)](#)

raita.com

Ominaisuudet pumppaamot:

- matalat mallit (1m korkeus), SMART ohjaus
- h2s ja hajua ehkäisevä muotoilu, tekniikka
- kestävä EN 12566-1- (VTT -S-06698-13),
EVS-EN 976-1: 2000, EVS-EN 976-2: 200
- eristyspaketti, hälytys-, etäseurantajärjestelmä
- tekniikka Raita, Siemens, Xylem, Gardner

Raita

D1800



PUMPPAAMOT



PUMP STATIONER



PUMPING STATIONS

24 h

D1800

Tanks D1200 mm are made of (PE) plastics (rotationm stability according to EN 12566-1 - VTT -S-06698-13)

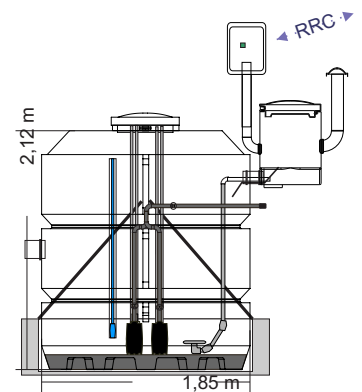
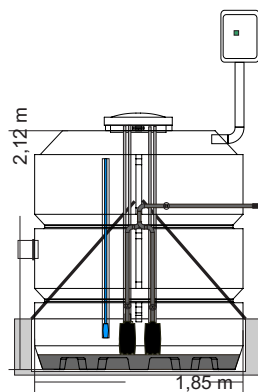
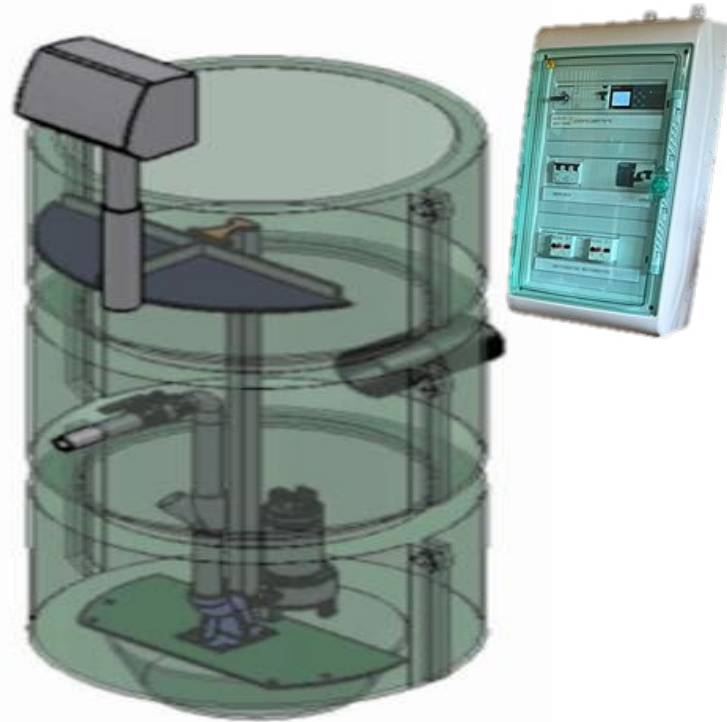
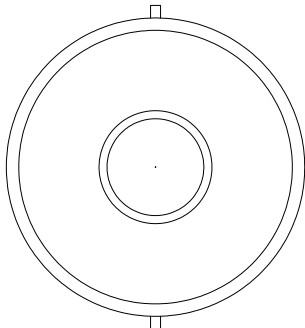
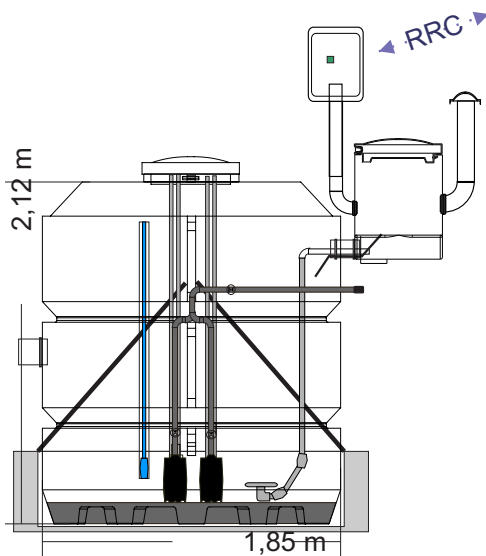

Länkar till ytterligare material:

[Manual RAITA pumping station](#)

[Modeller- ritningar](#)

[Sertificate PE](#)

[Sertificate glassfiber](#)

[Garanti \(10 år\)](#) (mark installation guide)

raita.com

Features - RAITA pumping stations:

- låga modeller (1m höjd), SMART kontroll, antilukt design, H2S-förhindrings teknik
- hållbar EN 12566-1- (VTT -S-06698-13),
- EVS-EN 976-1: 2000, EVS-EN 976-2: 200
- isoleringspaket, larm, rrc (fjärr) system
- teknik Raita, Siemens, Xylem, Gardner

Raita

D1800

24 h

D1800

Tanks D1200 mm are made of (PE) plastics (rotationm stability according to EN 12566-1 - VTT -S-06698-13)

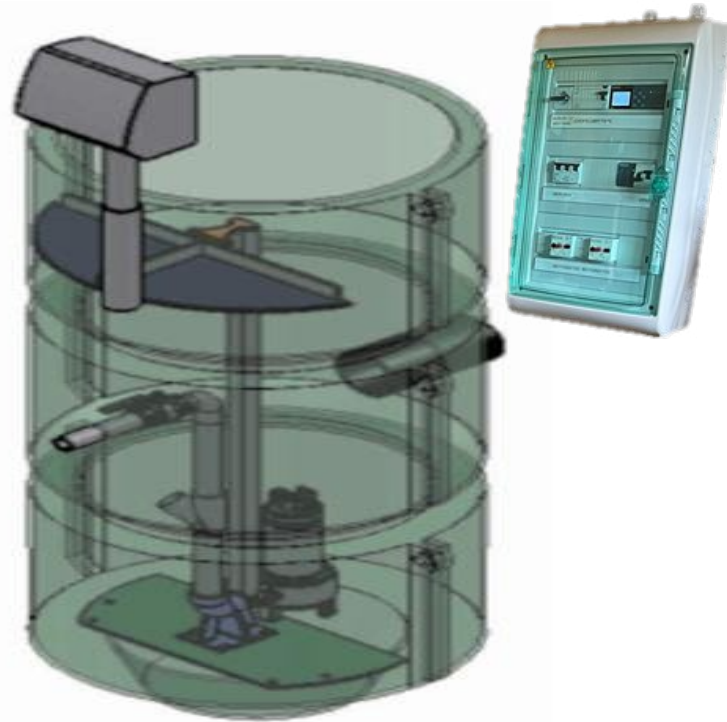
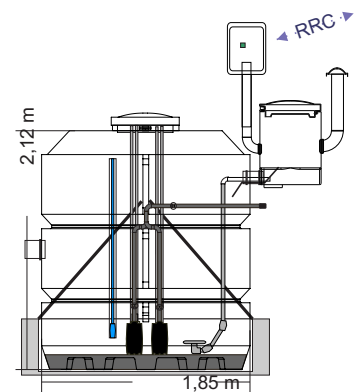
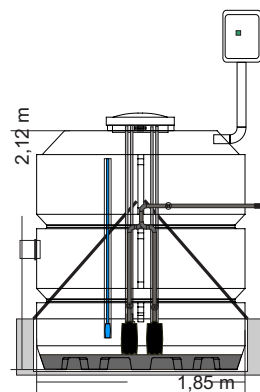
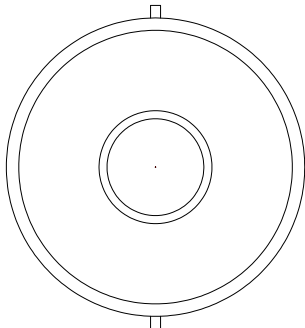
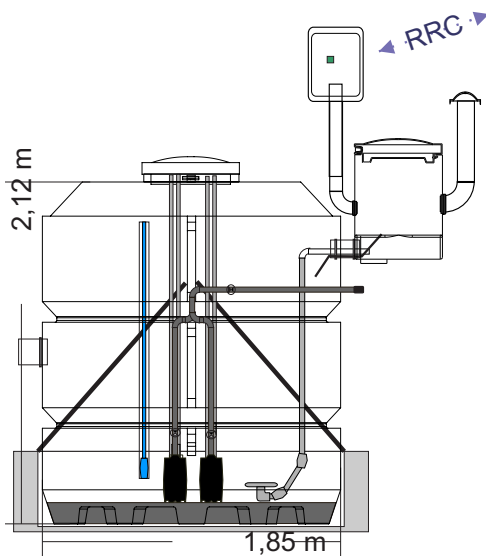

Links to additional material:

[Manual RAITA pumping stations](#)

[Modells - drawings](#)

[Certificate PE](#)

[Certificate glassfiber](#)

[Warranty \(10 years\)](#) (soil installing guide)

raita.com

Features - RAITA pumping stations:

- low models (1m height), SMART control
- anti-odor formulation, H2S-prevention
- durable EN 12566-1- (VTT -S-06698-13),
- EVS-EN 976-1: 2000, EVS-EN 976-2: 200
- insulation package, alarm, rrc (remote) system
- technology Raita, Siemens, Xylem, Gardner